

7050S

Maximum Security, Heavy Duty Electromechanical Deadlocking Latch For Swinging Doors

120 VAC Solenoid Actuated and Paracentric Key Unlocking – Jamb Mounted



Steel strike plate is zinc-plated.

Paracentric lever-tumbler key

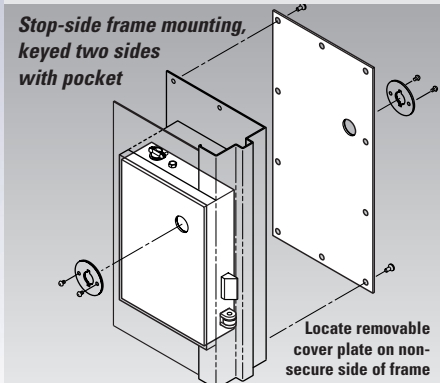
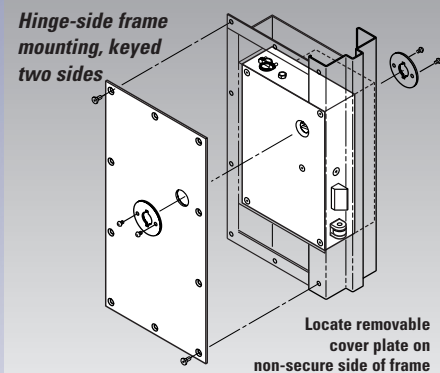
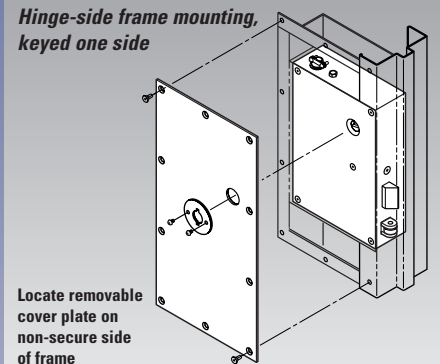

R.R. BRINK LOCKING SYSTEMS, INC.
500 Earl Road • Shorewood, IL 60404
Tel: 815-744-7000 • Fax: 815-744-7020
www.rrbrink.com

Application

- The 7050S solenoid actuated lock is an extra heavy weight electromechanical lock for use in openings subject to high traffic and/or where maximum attack resistance is a priority requirement. It is designed for jamb mounting in a grille or hollow metal frame (14 gauge minimum) with a custom fabricated and reinforced lock pocket (a.k.a. mortar box).
- The 7050S is recommended for remote control of maximum security locations in jails or prisons (e.g. cells, dayroom entries, and sally ports) or in other building types where openings in security perimeters must be equipped to withstand forced attack and/or constant usage.

- Electric unlocking is accomplished by a 120 VAC solenoid actuator. Latch retraction is snappy and accompanied by a noticeable clap sound.
- Mechanical latch retraction by RRBLs paracentric key/lever tumbler lock.
- With a hollow metal frame, the lock mechanism can be serviced with the lock in the frame by removing an access plate supplied by the frame manufacturer (see illustrations above).
- Impact tested to Security Grade 1 per ASTM F1450 and F1577.
- When used in exterior locations, moisture proofing of the lock enclosure is essential and an internal resistance-heating strip is recommended when the lock may be subjected to freezing conditions.

7050S

Maximum Security, Heavy Duty Electromechanical Deadlocking Latch For Swinging Doors

120 VAC solenoid actuated and Paracentric key unlocking – jamb mounted

Standard Features

- Key unlocking at all times with an integral R.R. Brink lever-tumbler lock.
- Lock case and cover made of 7 gauge steel, electroplated for corrosion resistance
- Working parts are of high strength bronze or stainless steel.
- A case hardened, zinc-plated steel latch (highly resistant to wear and sawing) with a full 3/4"-inch throw. 3/4" x 2" cross section at the locking shear point.
- Electroplated steel roller bolt deadlocks latch.
- Maintained Switch Latch Holdback (**MSLH**) function (For other available functions, see catalog page "Function Guide for Motorized Locks", item 2 under "General Comments".)
- Lock status switch (**LSS**) trips when the latch is in a deadlocked condition. Used in a signal circuit to indicate lock status – unlocked or deadlocked – via control panel lights and/or alarm devices. The LSS is also used to control an electrical interlock, which permits only one of a group of doors to be unlocked electrically at any time. *Note: For positive, tamper resistant signaling of a closed and deadlocked door, a sensitive door position (DPS) switch must be wired in combination with the LSS. Our DPS Nos. 201030 or 201090 are recommended.*
- Plug connectors are provided for ease in wiring and removal.
- Exposed fasteners – pinned "Torx" head

Electrical Data

- Solenoid – 120VAC – Laminate Design – Intermittent Duty – 60Hz standard – 10 ampere in-rush, 0.75 ampere seated.

NOTE: For applications utilizing 50Hz electrical input, consult factory prior to order. The life cycle of a 60Hz rated solenoid operated with 50Hz current is shortened due to possible overheating. Therefore, a non-standard 50Hz solenoid is recommended, particularly for high usage applications.

- Lock Status Switch – 125/250VAC, 5 amp, SPDT (Form C)



R.R. BRINK LOCKING SYSTEMS, INC.

500 Earl Road • Shorewood, IL 60404
Tel: 815-744-7000 • Fax: 815-744-7020
www.rrbrink.com

7052S Illustrated

Hinge-side mounting. Keyed one side

Note: This illustration is for information only. Do not use for construction. Door and frame preparation drawings and wiring schematics are available from the factory.

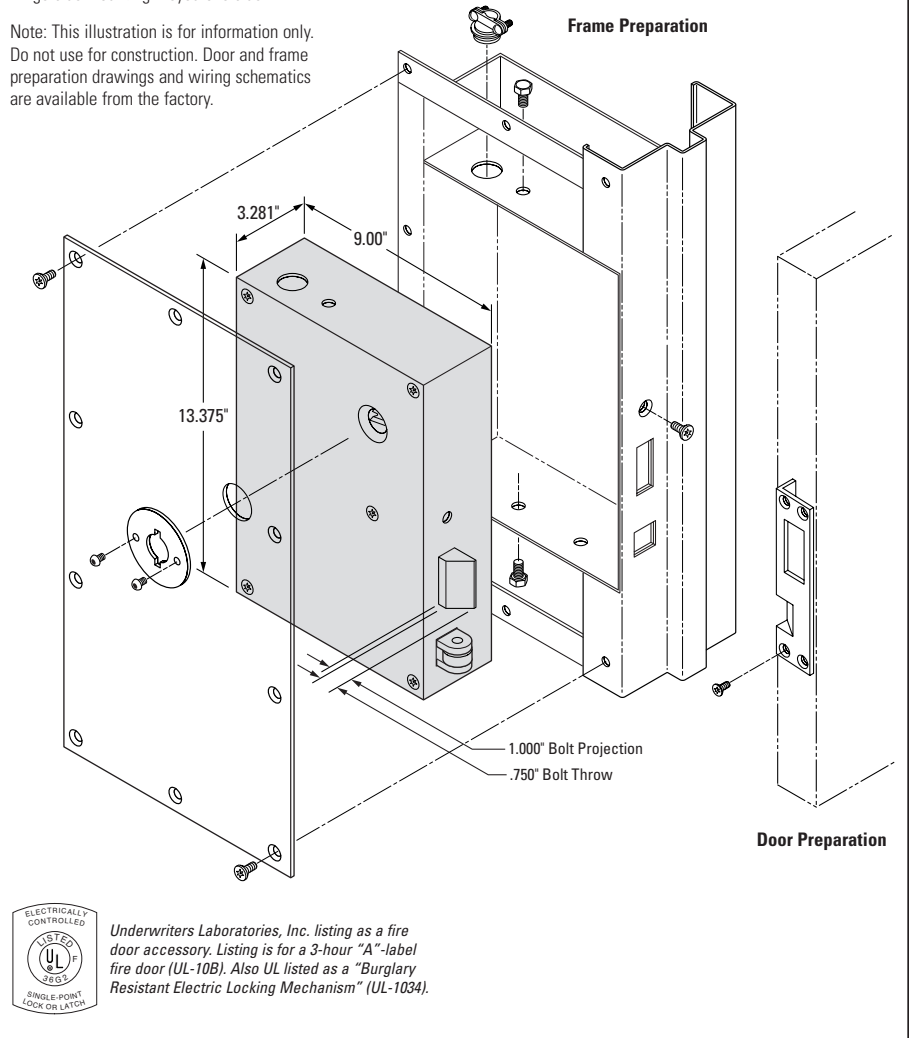

Underwriters Laboratories, Inc. listing as a fire door accessory. Listing is for a 3-hour "A"-label fire door (UL-10B). Also UL listed as a "Burglary Resistant Electric Locking Mechanism" (UL-1034).

Optional Accessories

- **Prison paracentric key** – order separately, not included with lock
- **Custom bolt projection** – consult factory
- **Escutcheon** – finish U.S. 32D
- **Cylinder Shield** – finish U.S. 32D

Custom Applications

Consult with our technical service personnel regarding custom applications such as retrofits to existing lock installations, special mounting situations and operational requirements.

Ordering Information

7050S – Solenoid Actuated Series

Model	Description
7052S	7050S keyed one side
7056S	7050S keyed both sides

