

## DOOR MOUNTED FOR SMALL SWINGING DOORS

Medium security.

# 1017A SNAPLATCH

1017A-1: KEYED ONE SIDE

### APPLICATION:

For food passes, observation shutters and other small swinging doors where snaplatching is desired.

### FUNCTION:

Key activated unlatching.  
Snaplatches upon closing.



## DOOR MOUNTED FOR SMALL SWINGING DOORS

Medium security.

### 1017A SNAPLATCH

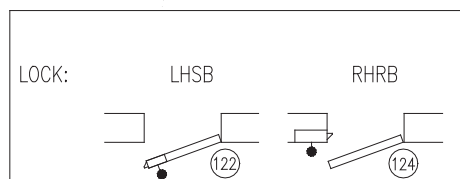
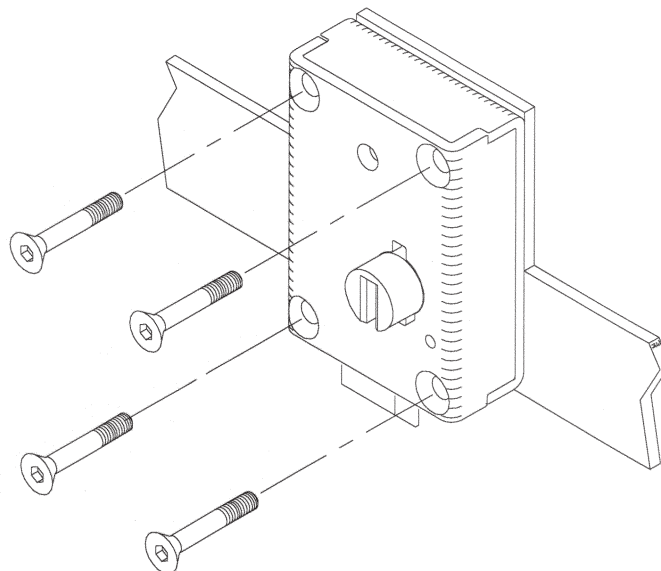

#### STANDARD FEATURES:

- Automatic snaplatch
- Six heavy-duty tumblers
- Mounting fasteners

#### OPTIONAL FEATURES:

**EXTENDED BOLT** - Used for hollow metal door mounting. Specify "1 inch".

**THUMBTURN** - Retracts latchbolt without key. Specify "1017AT".

#### HOW TO ORDER:

Specify:

1. Quantity
2. Key code instructions

#### TECHNICAL DATA:

- **STANDARD FINISH:**  
Galvanized
- **COVER:** Steel
- **CASE:** Steel
- **LATCHBOLT:** Steel
- **PARACENTRIC CYLINDER:**  
Silicon bronze/  
copper alloy
- **TUMBLERS:** Spring tempered brass. Tumblers actuated by phosphor bronze springs, six tumblers per lock
- **LOCK SIZE:**  
4.4" L x 3.15" H x 1.35" TK
- **LOCK WEIGHT:** 3 lbs.
- **LATCHBOLT SIZE:**  
1-1/2" H x 3/4" TK
- **LATCHBOLT:**  
5/8" extended  
1/2" travel

